

ELECTRIC PLANETARY HOISTS

DC1200

1,200 lbs Capacity

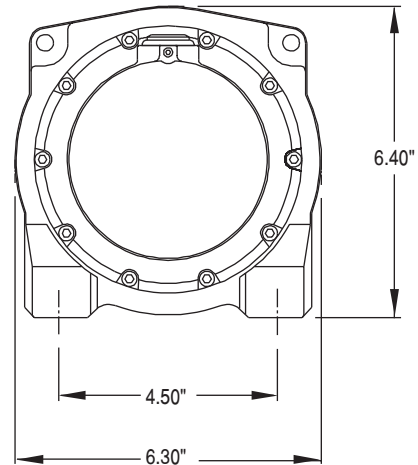
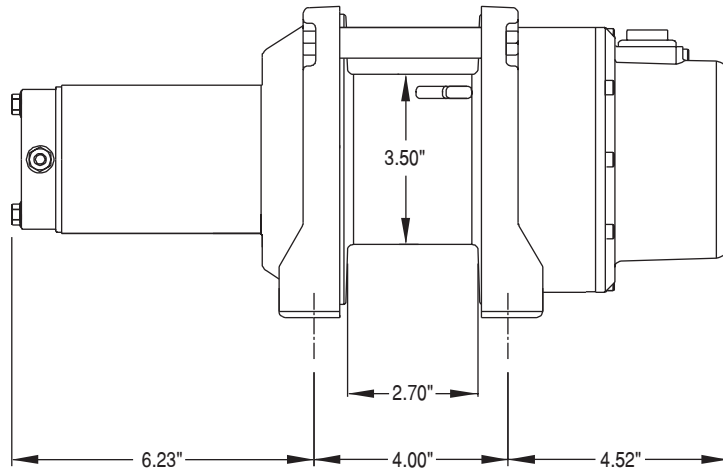

FEATURES

- Compact Design
- 3-Stage Planetary Reduction
- Dual Cone Brake
- Simple Wire Rope Attachment
- Rated for Hoisting

Wire Rope Capacity

3/16"
99'

PERFORMANCE

Specifications			Multi-Layer Performance			First Layer Performance		
Motor Type	Motor HP	Shipping Weight	Layer	Load (lbs)	Speed (fpm)	Load (lbs)	Speed (fpm)	Amp Draw
12V	1.3	25 lbs	1	1200	18.0	0	30.0	27
			2	1089	20.0	500	25.0	80
			3	997	22.0	750	22.0	106
			4	919	23.0	1200	18.0	153
24V	1.3	25 lbs	1	1200	18.0	0	30.0	13
			2	1089	20.0	500	25.0	38
			3	997	22.0	750	22.0	53
			4	919	23.0	1200	18.0	80

Performance based on intermittent duty cycles.

CAUTION: The final determination as to the suitability of this product for any purpose is solely that of the user. These products are not to be used to lift people or to lift anything over people.

ALLIED POWER PRODUCTS, INC.

THE WINCH & HOIST SPECIALISTS

6590 SW Fallbrook Place, Beaverton, OR 97008

(503) 626-0654 Fax (503) 646-1996

www.alliedpower.com